

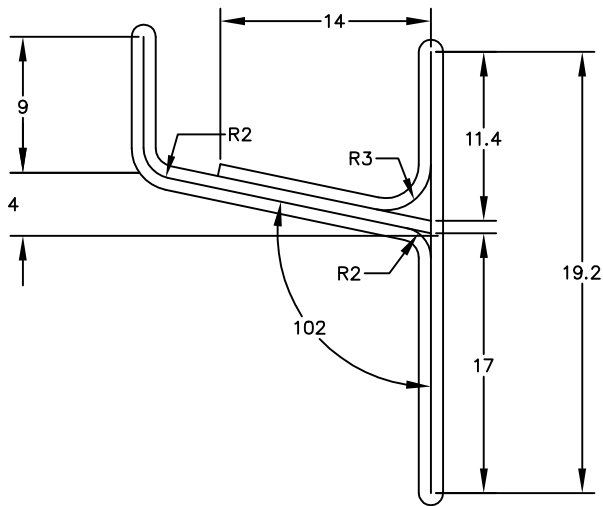

STAR AUTO INDUSTRIES
G/2,G/3,G/8 ANSA INDUSTRIAL ESTATE
SAKI VIHAR ROAD, SAKI NAKA



SCALE 2:1

DIVISION GLASS GUIDE CHANNEL

COMPANY : TATA MOTORS

PROJECT : INDICA

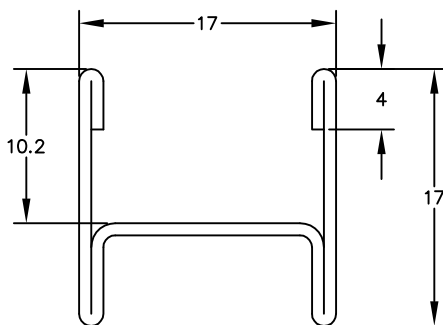

SCALE 2:1

DIVISION GLASS GUIDE CHANNEL

COMPANY : MAHINDRA & MAHINDRA

PROJECT : ARMADA



STAR AUTO INDUSTRIES
G/2,G/3,G/8 ANSA INDUSTRIAL ESTATE
SAKI VIHAR ROAD, SAKI NAKA

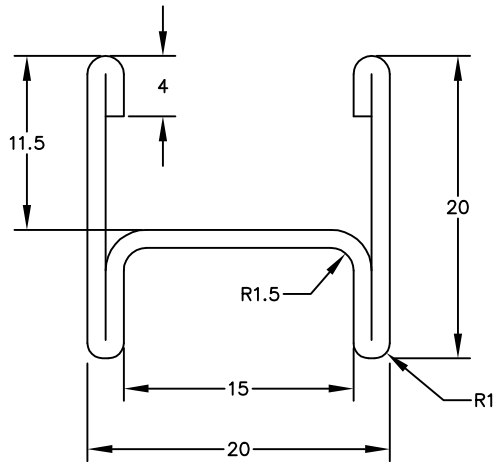

SCALE 2:1

DIVISION BAR

COMPANY : PAL-PEUGOT

PROJECT : PAL-PEUGOT 309

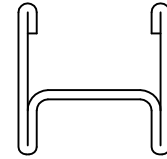

SCALE 1:1

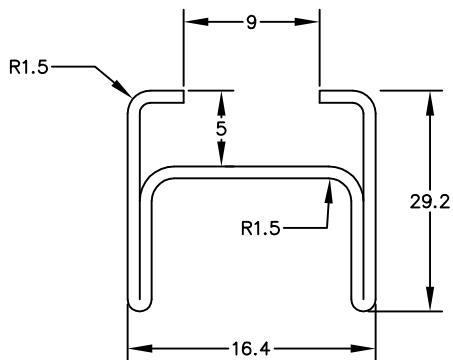

SCALE 2:1

QUARTER GLASS VERTICAL

COMPANY : PREMIER AUTOMOBILES

PROJECT : PREMIER PADMINI

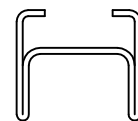

SCALE 1:1



STAR AUTO INDUSTRIES
G/2,G/3,G/8 ANSA INDUSTRIAL ESTATE
SAKI VIHAR ROAD, SAKI NAKA

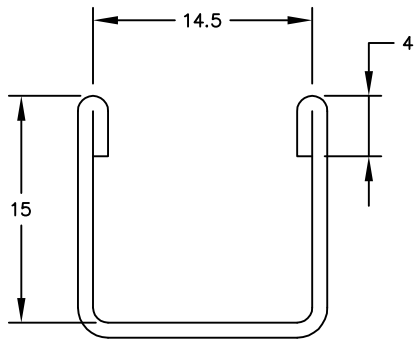

SCALE 2:1

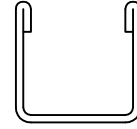

SCALE 1:1

GLASS RUN CHANNEL

COMPANY : ASHOK LEYLAND

PROJECT : IVECO CARGO

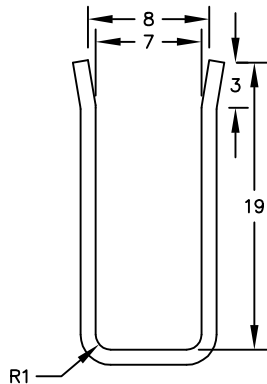

SCALE 2:1



SCALE 1:1

GLASS LIFTING CHANNEL

COMPANY : ASHOK LEYLAND

PROJECT : IVECO CARGO



STAR AUTO INDUSTRIES
G/2,G/3,G/8 ANSA INDUSTRIAL ESTATE
SAKI VIHAR ROAD, SAKI NAKA

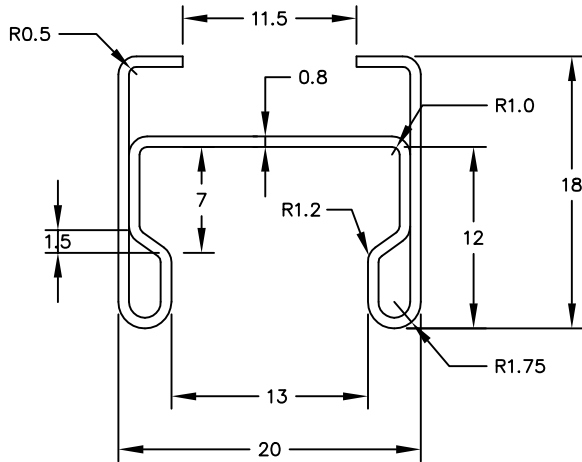

SCALE 2:1

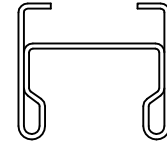

SCALE 1:1

REAR GLASS GUIDE CHANNEL

COMPANY : TATA MOTORS

PROJECT : SUMO, CREW CAB, ESTATE

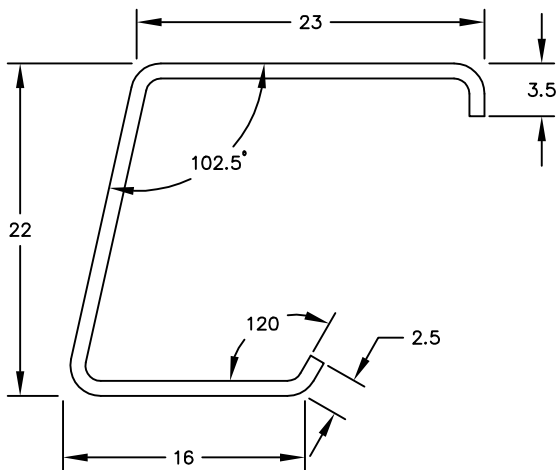

SCALE 2:1

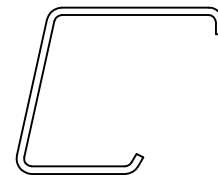

SCALE 1:1

GLASS GUIDE CHANNEL

COMPANY : TATAMOTORS

PROJECT : INDICA



STAR AUTO INDUSTRIES
G/2,G/3,G/8 ANSA INDUSTRIAL ESTATE
SAKI VIHAR ROAD, SAKI NAKA

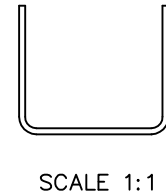
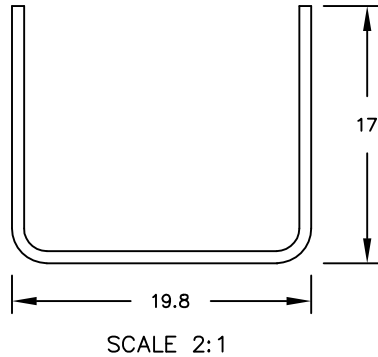

SCALE 1:1

GLASS RUN CHANNEL

COMPANY : MAHINDRA & MAHINDRA

PROJECT : ARMADA, GRAND

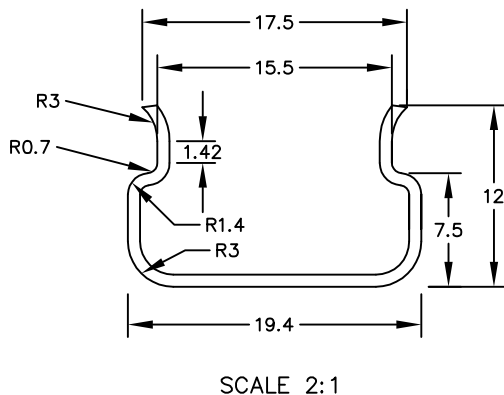

SCALE 1:1

GLASS GUIDE CHANNEL

COMPANY : TATA MOTORS

PROJECT : SUMO, SIERRA, MOBILE, 709



STAR AUTO INDUSTRIES
G/2,G/3,G/8 ANSA INDUSTRIAL ESTATE
SAKI VIHAR ROAD, SAKI NAKA

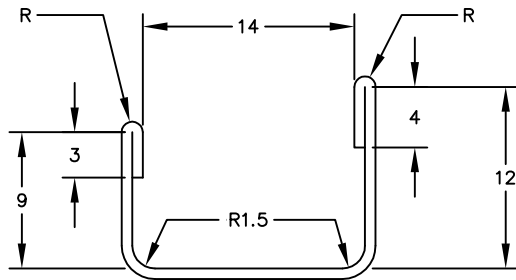

SCALE 2:1

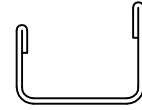

SCALE 1:1

GLASS RUN CHANNEL

COMPANY : PAL-PEUGOT

PROJECT : PAL-PEUGOT 309

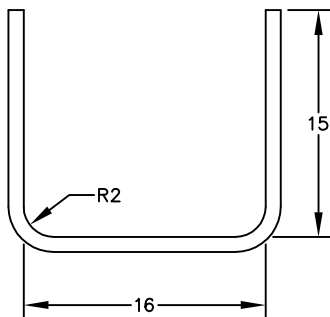

SCALE 2:1

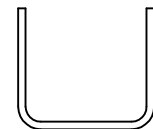

SCALE 1:1

GLASS GUIDE CHANNEL

COMPANY : TATA MOTORS

PROJECT : SAFARI



STAR AUTO INDUSTRIES
G/2,G/3,G/8 ANSA INDUSTRIAL ESTATE
SAKI VIHAR ROAD, SAKI NAKA

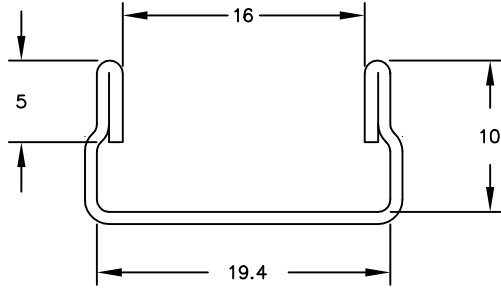

SCALE 2:1

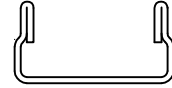

SCALE 1:1

SASH

COMPANY : MAHINDRA & MAHINDRA

PROJECT : VOYAGER

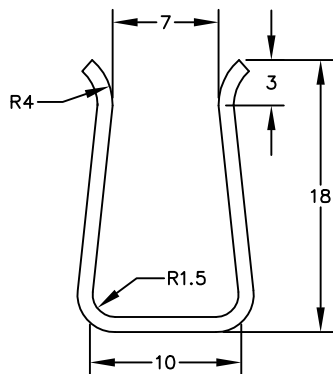

SCALE 2:1



SCALE 1:1

GLASS RUN CHANNEL

COMPANY : PREMIER AUTOMOBILES

PROJECT : PREMIER PADMINI



STAR AUTO INDUSTRIES
G/2,G/3,G/8 ANSA INDUSTRIAL ESTATE
SAKI VIHAR ROAD, SAKI NAKA

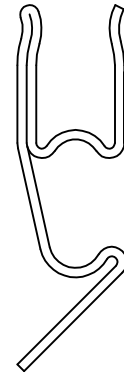
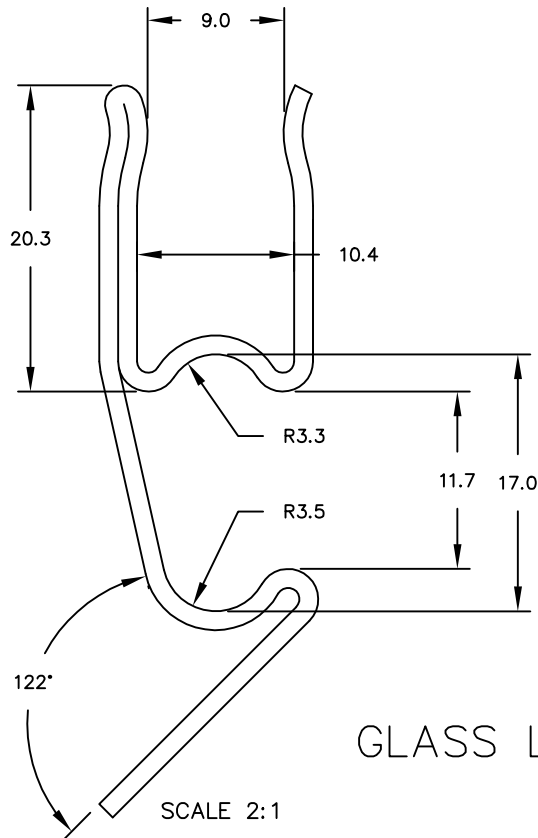

SCALE 1:1

GLASS LIFTING CHANNEL

COMPANY : FORCE MOTORS

PROJECT : TEMPO TRAVELLER

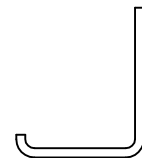
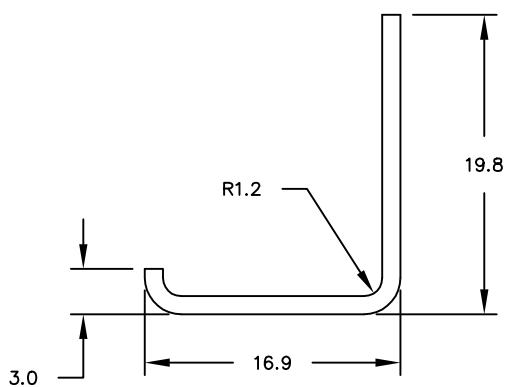

SCALE 1:1

SCALE 2:1

GLASS RUN CHANNEL

COMPANY : FIAT INDIA

PROJECT : PALIO



STAR AUTO INDUSTRIES
G/2,G/3,G/8 ANSA INDUSTRIAL ESTATE
SAKI VIHAR ROAD, SAKI NAKA

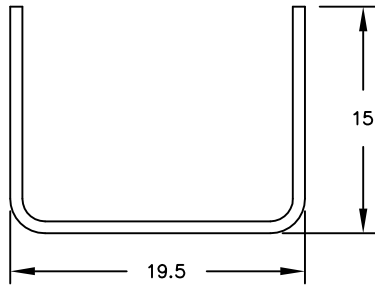

SCALE 2:1

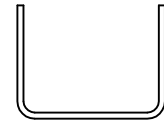

SCALE 1:1

GLASS RUN CHANNEL

COMPANY : MAHINDRA & MAHINDRA

PROJECT : SCORPIO

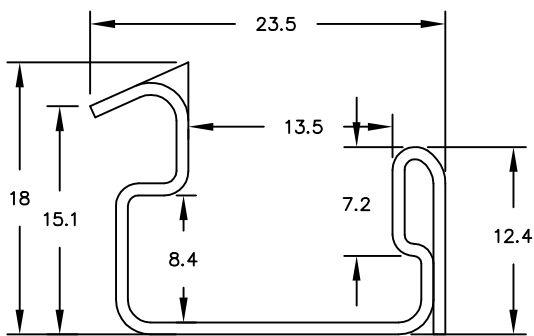

SCALE 2:1

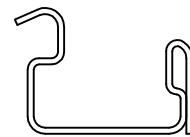

SCALE 1:1

SASH REAR DOOR CENTRE

COMPANY : HM / MITSUBISHI

PROJECT : LANCER



STAR AUTO INDUSTRIES
G/2,G/3,G/8 ANSA INDUSTRIAL ESTATE
SAKI VIHAR ROAD, SAKI NAKA

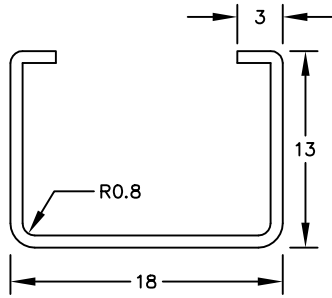

SCALE 2:1

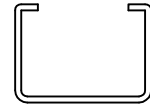

SCALE 1:1

QUARTER GLASS OUTER

COMPANY : TATA MOTORS

PROJECT : 407

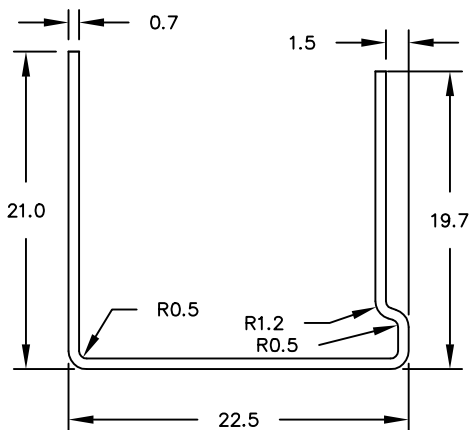

SCALE 2:1

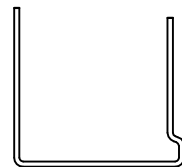

SCALE 1:1

GLASS GUIDE CHANNEL

COMPANY : ICML

PROJECT : RHINO